



VA250-R

125Wrms DAB/250W p-synk VHF TV Amplifier

VA250-R amplifier embodies LD-MOS and TETRAFET technologies and is designed for both digital and analog applications. The unit is the state of the art in terms of easy assembly, reliability and performances. The complete unit can assure the compliance to all relevant international standards.

- 250Wps Out
- 125Wrms Out DAB
- BroadBand (170-230 MHz)
- Designed for SKD sales
- Internal cabling free
- Easy maintenance without special tools
- RS232-RS485 interface
- Control software included
- Extremely strong mechanical structure



BLOCK DIAGRAM

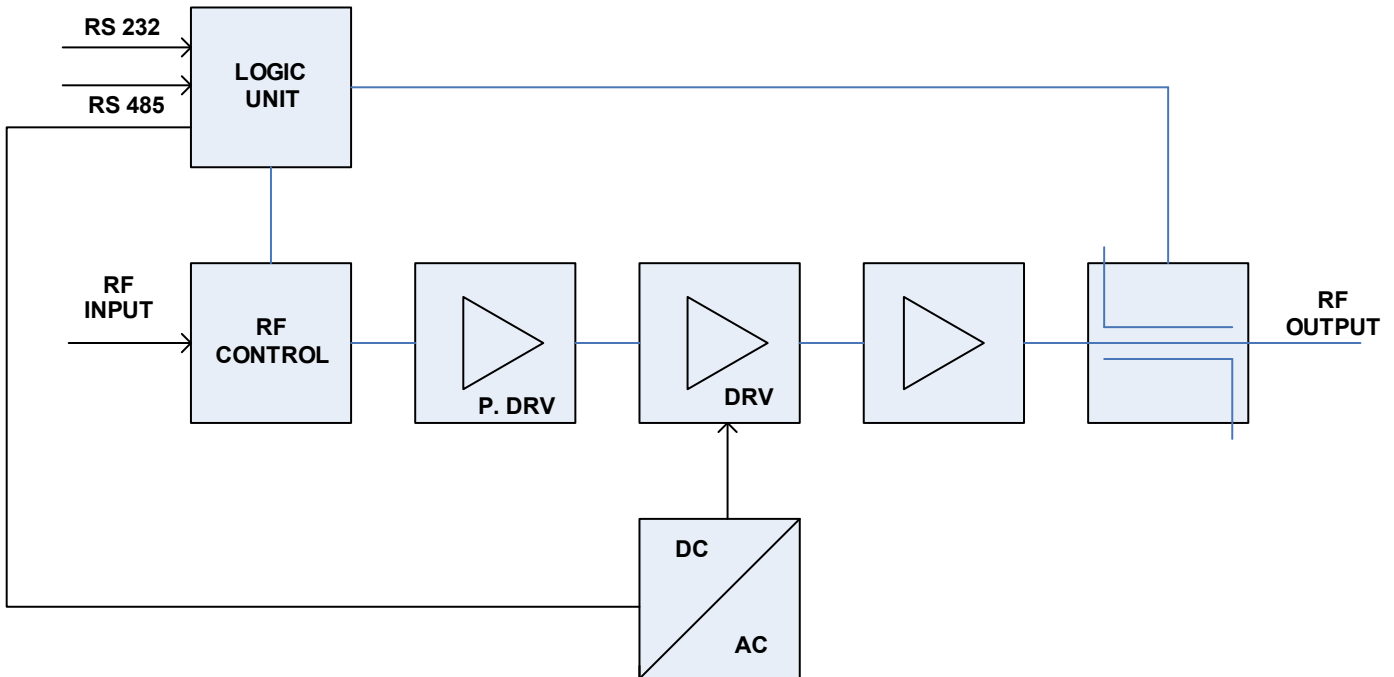



VA250-R

ELECTRICAL DATA

Voltage Supply	220Vac +15% -20% nominal 100-240Vac 50-60Hz for Pout up to 125Wrms 176-240Vac 50-60Hz for Pout over 125Wrms
Power Consumption	800W @250W Ps Black Field @200MHz (typ.) 600W @125Wrms DAB @200 MHz (typ.)
Current Consumption	3.6 A max @ 220 V analog application
Operating Temperature	0 to +45 °C
Humidity	Up to 90% (non condensing)
Gain Stability	-
Gain	56dB ±2dB nominal
Power Out (@1dB compression)	Min. 350W (Typ. 400W)
Input Return Loss	Min. -16dB (Typ. -20dB)
Output Return Loss	Min. -18dB (Typ. -20dB)
Load Mismatch (CW 250W F₀ 230MHz VSWR=2:1) all phase angle	No degradation
P_{out} Common Ampl.	250W Ps IMD < -45dB Red Field (without pre correction)
P_{out} Separate Ampl.	350W sink compression < 1dB
P_{out} DAB	125Wrms shoulder < -28dBc (without pre correction)
P_{out} DVB-T	80Wrms shoulder < -30dBc (without pre correction)
P_{out} PEP	400W IMD < -27 dBc

MECHANICAL DATA AND INTERFACES

Dimensions	119" 3HU std 400mm depth ^[1]
Weight	15 Kg.
RF in	N connector rear panel
RF out	N connector rear panel
RF mon	SMA connector rear panel
RS232	D 9 poles front and rear panel
RS485	D 9 poles rear panel
Local Enable	Switch front panel Two-pole connector rear panel

REMOTE CONTROL

Enable	RF Enable ON/Stand By
GAIN (option)	Gain setting

¹ WARM UP:

To achieve the stability vs temperature correct value when the equipment is cold, please wait 30 minutes at least after switching on



VA250-R

READABLE DATA BY REMOTE COMPUTER OR CONTROL LOGIC UNIT (THROUGH RS232/RS485)

STATUS/ALARMS	NOTES
Enable	ON/STAND BY
RF Faults	ACTIVE if Gain < 6dB referred to nominal
°C max	ACTIVE when RF Thermal Protection is ON
Pin max	ACTIVE when RF Overdrive Protection is ON
VSWR max	ACTIVE if VSWR max Protection is ON
I max	ACTIVE when Current is too high
MEASUREMENTS	
RF in	Input Power in mW (PS for analog, RMS for DAB)
RF out	Output Power in W (PS for analog, RMS for DAB)
RF DRV	RF Driver Output in W (PS for analog, RMS for DAB)
RF Heatsink Temperature	Temperature in °C
IDC Driver	Value in A
IDC Final Stage	Value in A
VDC	PS Output Voltage

SELF PROTECTIONS

RF Thermal Protection	
Overdrive	Pin max must be set on the working channel with the used DAB or Analog signal
VSWR max	VSWR max must be set on the working channel with the used DAB or Analog signal
I max	



VA250-R

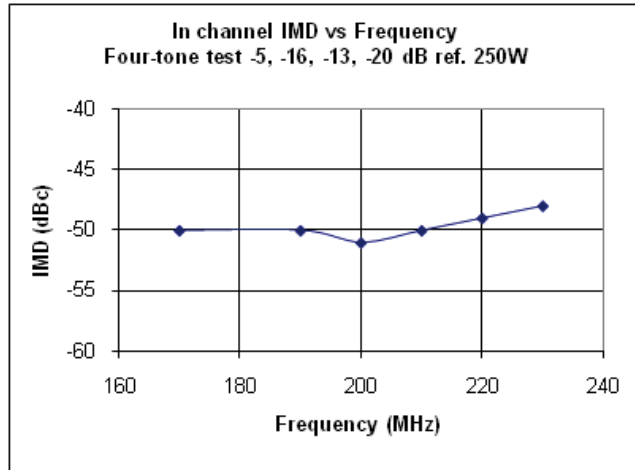

Without pre correction

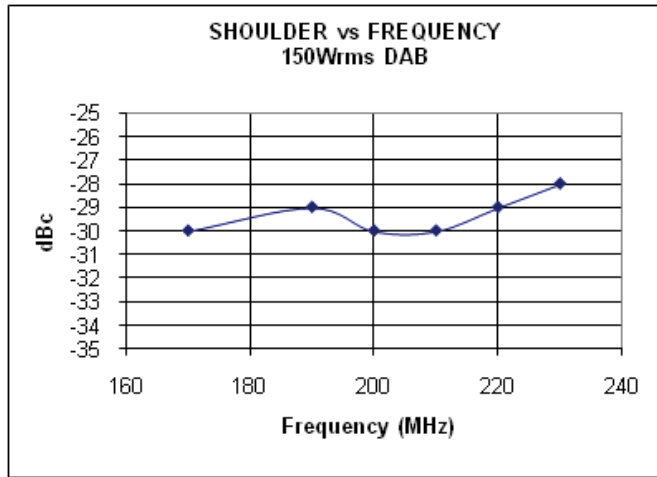

Without pre correction

Front Panel

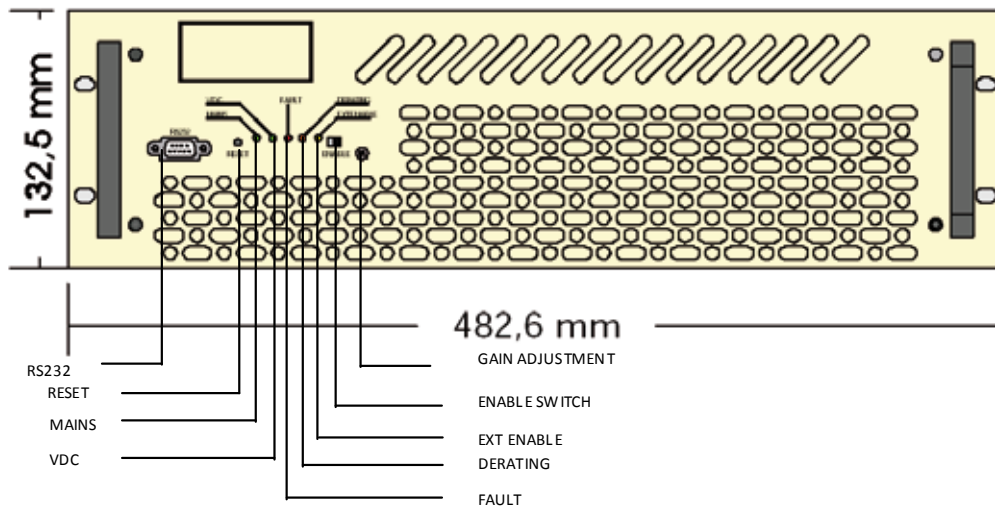



VA250-R

Side View

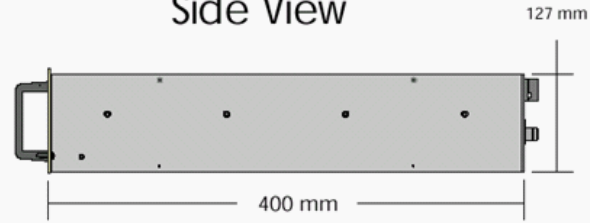

Top View



Rear Panel

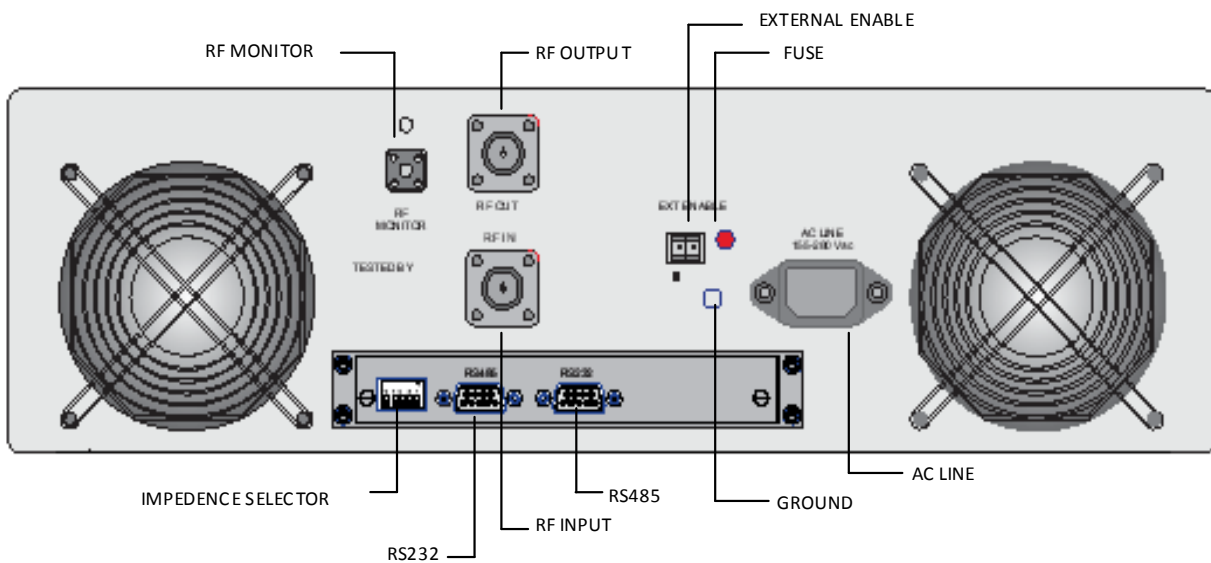



VA250-R

IMPORTANT NOTICE

ONAIR RESERVE THE RIGHT TO MAKE CHANGES TO THE PRODUCT(S) OR INFORMATION CONTAINED HEREIN WITHOUT NOTICE. ONAIR ASSUMES NO RESPONSIBILITY FOR ANY ERRORS WHICH MAY APPEAR IN THIS DOCUMENT.

WARRANTY INFORMATION APPLICABLE TO THE PRODUCT IDENTIFIED HEREIN IS AVAILABLE UPON REQUEST. NOTHING CONTAINED HEREIN SHALL CONSTITUTE A WARRANTY, REPRESENTATION OR GUARANTEE OF ANY KIND. ONAIR EXPRESSLY DISCLAIMS ALL OTHER WARRANTIES, EXPRESS AND/OR IMPLIED INCLUDING BUT NOT LIMITED TO WARRANTIES OF MERCHANTABILITY, AND OF FITNESS FOR A PARTICULAR PURPOSE, USE OR APPLICATION.

No part of this document may be copied or reproduced in any form or by any means without the prior written consent of ONAIR.

WARNING

ONAIR PRODUCTS ARE NOT INTENDED FOR USE IN LIFE SUPPORT APPLIANCES, DEVICES OR SYSTEMS. USE OF A ONAIR PRODUCT IN ANY SUCH APPLICATION WITHOUT WRITTEN CONSENT IS PROHIBITED