



1-2 GHz DIGITAL STUDIO TRANSMITTER LINK DVL SERIES

GENERAL DESCRIPTION -

- **The DVL Series Digital Television Links** are designed to operate in the 863 MHz to 2300 MHz range to transfer multiple high quality digital Video and Audio programs in the same user-defined RF channel bandwidth.
- **Ultra low phase noise oscillators** and a powerful linearity pre-corrector allow minimizing the Bit Error Rate (BER) also using the maximum spectrum efficiency modulation systems (BPSK, QPSK, 8PSK or QAM).
- **Bit-rate programmability.** The digital modulators and demodulators have a fully programmable bit rate allocation for each program to widely define the quality and bandwidth of the modulation: this to guarantee the maximum flexibility in all applications.
- **Indoor & Outdoor.** The UC & DC Series microwave up & down-converters are available in indoor or outdoor waterproof version for rear parabola mounting facility.
- **Analog or digital.** All the UC & DC Series microwave up & down converters are suitable for digital or analog operation, with full compatibility with existing analog IF modulators & demodulators. They are available with different IF frequency on request.
- **Full metering,** control, setting and system diagnostic is available on the front panel.
- **Digital networks compatibility.** The DVL links are suitable for being integrated in any analog or digital network with easy and direct connection to satellite digital receivers and terrestrial digital or analog broadcasting transmitters.

POINT TO POINT DIGITAL MICROWAVE LINK CONFIGURATION

- **Generals.** The new ONAIR Digital Video Microwave Links allow a top quality Video and Audio connection with possibility of multichannel configuration for a very spectrum efficient and cost effective solution.

The full system is easily user configurable to optimize the RF band efficiency and the Video and Audio characteristics for each application (contribution links, distribution links, mobile digital links, etc...).

- **To compose a digital microwave link** you need to use the following equipments:

- An IF Modulator/Encoder (DVL-IF series with 1, 2, 3 or 4 Video channels capacity and 2, 4,6 ,8 Audio channels capacity)
- An IF to Channel microwave up-converter/amplifier with an output power suitable for the link connection (UC series with operating frequency and power as indicated in the table below)
- A Channel to IF microwave down-converter/preamplifier (DC series with operating frequency as indicated in the table below)
- An IF Receiver/Decoder (DVL-Rx series with 1,2,3,4 Video channels capacity and 2,4,6,8 Audio channels capacity)
- 2 antennas properly dimensioned for the link coverage distance

See a block diagram for a 4 video + 8 audio programs link:



1-2 GHz DIGITAL STUDIO TRANSMITTER LINK DVL SERIES

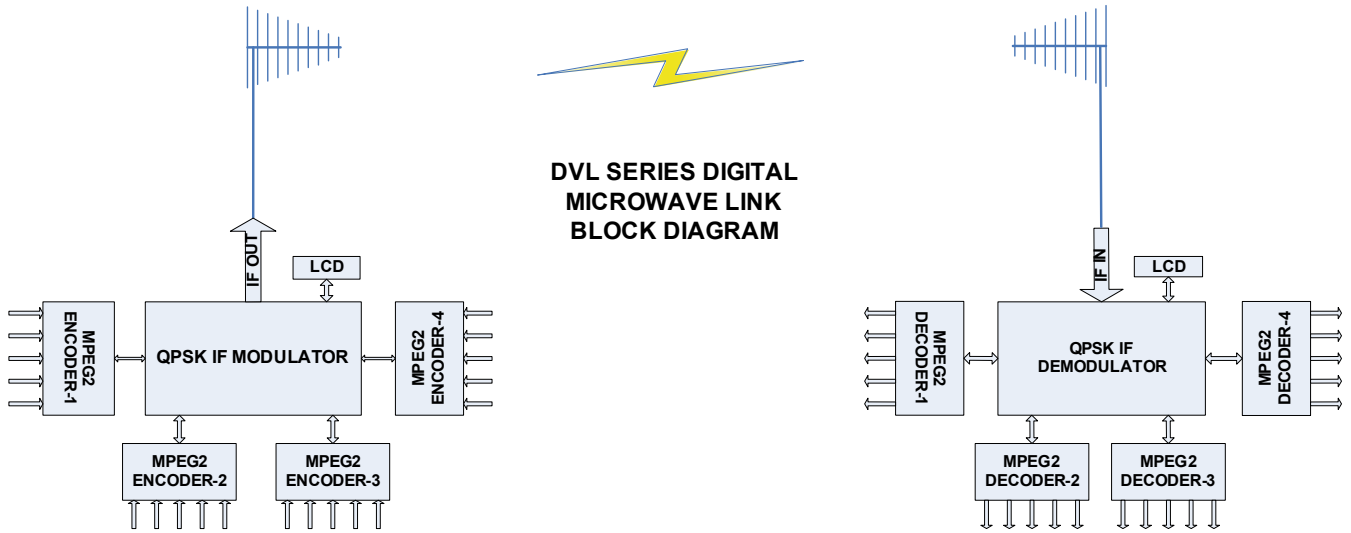

GENERAL TECHNICAL FEATURES

- Complete solution for TV&FM Radio link requirements
- Consisting Encoder, Decoder, Tx&Rx Antennas and installation accessories
- Operating Frequency from 863 to 2300 MHz
- Accepts up to 4 Video + 8 Audio Channels
- Output Power: 5W
- Add / Modify Tables (NIT, SDT...)
- Automatic Bit Rate Adaptation
- Forward Error Correction (RS 188/204; code rates 1/2 to 7/8; convolutional interleaving)
- Symbol Rate up to 20MS/s
- Tuning 1 kHz step
- Compliant to ETS300421 (DVB-S)

To include more than 4 Video and 8 Audio programs is possible to use external multiplexers and de-multiplexers for very high capacity networks.



1-2 GHz DIGITAL STUDIO TRANSMITTER LINK DVL SERIES

TRANSMITTER SECTION DVL/IF/XX

TECHNICAL CHARACTERISTICS

VIDEO INPUT

Video Input Connector	BNC
Video Input Level	1Vp-p
Impedance	75 Ohm
Video format	PAL/NTSC/SECAM
Selectable Encoding Bit Rate	4:2:0 1.5 to 15Mbps
Audio Input Connector	XLR-3

AUDIO INPUT

Audio Input Level	+10dBm max
Impedance	> 100kOhm, Unbalanced
Audio Frequency Interval	25 Hz-15 KHz
Audio Frequency Response	+/-0,5 dB max.
Operating Modes	Stereo, Joint Stereo, Dual channel and single Channel
Sampling Frequencies	32kHz, 48kHz, 56kHz, 64kHz, 80kHz, 96kHz, 112kHz 128kHz, 160kHz, 192kHz, 224kHz, 256kHz, 320kHz, 384kHz

MODULATOR

Modulation	QPSK
Inner FEC Code Rates	1/2, 2/3, 3/4, 5/6 and 7/8
Outer Code	188/204 Reed Solomon
Modulation Error Rate	>25 dB
Symbol Rate	1-45 Msymbol/s in 1 kSymbol-steps
Programming Resolution	1 Baud
Frequency	70 -482 MHz
Return Loss	>10 dB
Spurious	>60dBc/4kHz
Connector	F-type in KU band, N type in ISM band

POWER

Line Input Voltage Range	185-265 VAC
Line Frequency	50 Hz +/-%10

ENVIRONMENTAL

Temperature Range	15 0C to 50 0C
Humidity	% 30-80

RECEIVER SECTION DVL/Rx/XX

TECHNICAL CHARACTERISTICS

General Specifications:

- LCD display (2x16 characters)
- Front Panel Keypad / Keypad lock
- Selectable BER value / signal strength display
- Automatic FEC detection, carrier tracking, power-on reset
- LED indicators (Power, Lock, Alarm)



1-2 GHz DIGITAL STUDIO TRANSMITTER LINK DVL SERIES

Optional BISS decoding
C- / KU band reception
Dynamic PMT feature
Optional DVB Subtitle feature
PAL, SECAM and NTSC systems

RF Characteristics:

Input Level: -25 dBm to -65 dBm
Input Frequency: 863-2300 MHz
Modulation: QPSK
Symbol Rate: 1-45 M symbols/sec (M bauds)
FEC Coding: 1/2, 2/3, 3/4, 5/6, 7/ automatic selection
Input Impedance: 75 Ω
LNB Power Supply: 13/18 V polarity switching, plus 22 kHz
LNB Current: 400 mA, short circuit protected
Input Connector: F- type, female
Loop Out Connector: F- type, female

Video Compression:

Data Rate: 1.5 – 15 Mbps
Compression Type: MPEG-2, 4:2:0
Video Format: 4:3

Video Output:

Video Format: Composite PAL/NTSC/SECAM
Output Level: 1 Vpp menu adjustable
Output Impedance: 75 Ohm
Chroma- Luma Gain : < 5 %
Chroma- Luma Delay : < 25 ns
Luminance non-linearity : < 4 %
Connector type: BNC, female
Monitor output: BNC, female

Audio Compression:

Compression Type: MPEG-1 Layer-I, II
Output Modes: Stereo, Dual Mono, Mono
Sampling Rate: 32, 44.1 and 48 kHz

Audio Outputs:

Frequency range: 16Hz-22 kHz

ORDER CODES

DVL1/5/12	1 GHz Digital Video Link, 1 Video+2 Audio, 5 W Output, Logarithmic Antenna
DVL1/5/24	1 GHz Digital Video Link, 2 Video+4 Audio, 5 W Output, Logarithmic Antenna
DVL1/5/36	1 GHz Digital Video Link, 3 Video+6 Audio, 5 W Output, Logarithmic Antenna
DVL1/5/48	1 GHz Digital Video Link, 4 Video+8 Audio, 5 W Output, Logarithmic Antenna
DVL2/5/12	2 GHz Digital Video Link, 1 Video+2 Audio, 5 W Output, Logarithmic Antenna
DVL2/5/12	2 GHz Digital Video Link, 2 Video+4 Audio, 5 W Output, Logarithmic Antenna
DVL2/5/12	2 GHz Digital Video Link, 3 Video+6 Audio, 5 W Output, Logarithmic Antenna
DVL2/5/12	2 GHz Digital Video Link, 4 Video+8 Audio, 5 W Output, Logarithmic Antenna