

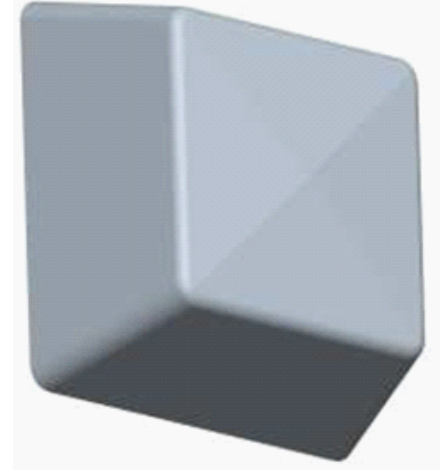

087

Two Dipoles Panel 470÷860 MHz 90° - pol.H

Type	087
Frequency	470÷860 MHz
Impedance	50 Ohm
V.S.W.R.	< 1.12
Gain	8.5 dBd
HPBW	
E-plane	± 30°
H-plane	± 28°
Front to back	> 20 dB
Polarization	Vertical or Horizontal
Input connector	7/8" EIA Flange miter elbow
option 1	N female miter elbow
option 2	7/16 miter elbow
Max power	1.5 kW with 7/8" EIA flange
Survival wind velocity	200 km/h
Wind load at 160 km/h	400 N
Dimensions	52x52x30 cm
Net weight	5 kg



Panel reflector is made of coated fibreglass. Stainless steel nuts and screws. All metallic parts are connected to the ground. The passivated brass dipoles and feeding lines are completely protected by a backed fibreglass radome; standard color Gray (different colors available on request). Input connector is nickel plated while the internal lines are made of silver plated brass.

RADIATION PATTERN

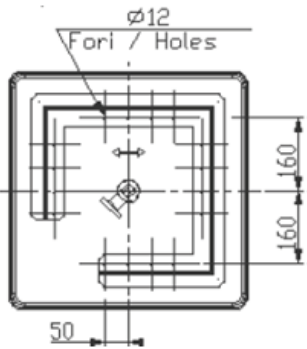
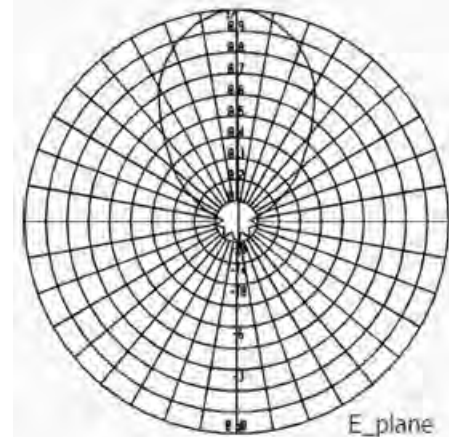
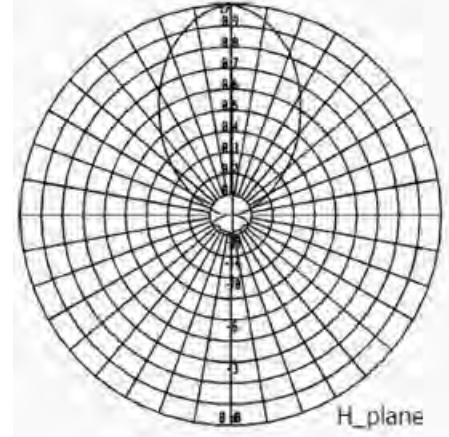

MOUNTING SYSTEM

On frame according to the mounting lay-out beside.

Pole mount available on request

This panel can be used in vertical or horizontal polarization to set up systems having directive, semidirective and omnidirectional diagrams.

Systems made up with 087A panels can be designed on customer specifications.